

Архангельск (8182)63-90-72
 Астана (7172)727-132
 Астрахань (8512)99-46-04
 Барнаул (3852)73-04-60
 Белгород (4722)40-23-64
 Брянск (4832)59-03-52
 Владивосток (423)249-28-31
 Волгоград (844)278-03-48
 Вологда (8172)26-41-59
 Воронеж (473)204-51-73
 Екатеринбург (343)384-55-89
 Иваново (4932)77-34-06

Ижевск (3412)26-03-58
 Иркутск (395)279-98-46
 Казань (843)206-01-48
 Калининград (4012)72-03-81
 Калуга (4842)92-23-67
 Кемерово (3842)65-04-62
 Киров (8332)68-02-04
 Краснодар (861)203-40-90
 Красноярск (391)204-63-61
 Курск (4712)77-13-04
 Липецк (4742)52-20-81

Киргизия (996)312-96-26-47

Магнитогорск (3519)55-03-13
 Москва (495)268-04-70
 Мурманск (8152)59-64-93
 Набережные Челны (8552)20-53-41
 Нижний Новгород (831)429-08-12
 Новокузнецк (3843)20-46-81
 Новосибирск (383)227-86-73
 Омск (3812)21-46-40
 Орел (4862)44-53-42
 Оренбург (3532)37-68-04
 Пенза (8412)22-31-16

Россия (495)268-04-70

Пермь (342)205-81-47
 Ростов-на-Дону (863)308-18-15
 Рязань (4912)46-61-64
 Самара (846)206-03-16
 Санкт-Петербург (812)309-46-40
 Саратов (845)249-38-78
 Севастополь (8692)22-31-93
 Симферополь (3652)67-13-56
 Смоленск (4812)29-41-54
 Сочи (862)225-72-31
 Ставрополь (8652)20-65-13

Казахстан (772)734-952-31

Сургут (3462)77-98-35
 Тверь (4822)63-31-35
 Томск (3822)98-41-53
 Тула (4872)74-02-29
 Тюмень (3452)66-21-18
 Ульяновск (8422)24-23-59
 Уфа (347)229-48-12
 Хабаровск (4212)92-98-04
 Челябинск (351)202-03-61
 Череповец (8202)49-02-64
 Ярославль (4852)69-52-93

<https://fanar.nt-rt.ru/> || frk@nt-rt.ru

S-NC

Group of taps optimized for machining on CNC machines with the use of synchronous tapping cycle. Designed for a wide spectrum of materials such as steels, stainless steels, cast iron, non-ferrous metals as well as superalloys.

Tool is made of **HSSE-PM** steel obtained in technology of powder metallurgy to guarantee homogenous structure that promotes high resistance to wear and tear.

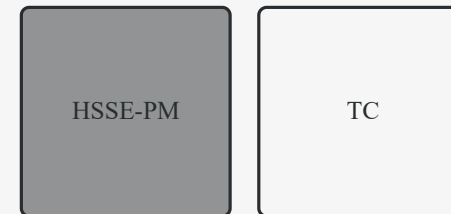

Application

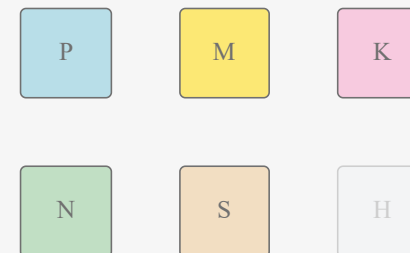

Variants

Variant

Type of hole

Type of chamfer

Type of grooves

Execution standard

B-TC			B (4-5P)	Spiral point	DIN-371
B-TC			B (4-5P)	Spiral point	DIN-374/DIN-376
C-R45-IK-TC			C (2-3P)	R45	DIN-371
C-R45-IK-TC			C (2-3P)	R45	DIN-374/DIN-376
C-R45-TC			C (2-3P)	R45	DIN-371
C-R45-TC			C (2-3P)	R45	DIN-374/DIN-376

S-NC B-TC DIN-371



HSSE-PM

TC

B (4-5P)

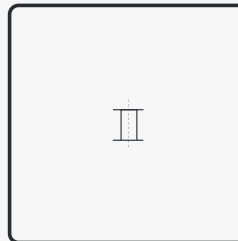

B-TC DIN-371

Taps dedicated to synchronous tapping.

Protection



Tools are protected against wear and tear by TC coat developed by Fanar. Applied in state-of-the-art HiPIMS technology that guarantees

homogenous coat structure and the highest crack resistance. Silicon contained in the coat allows machining hard and abrasive materials.

Select thread variant

M

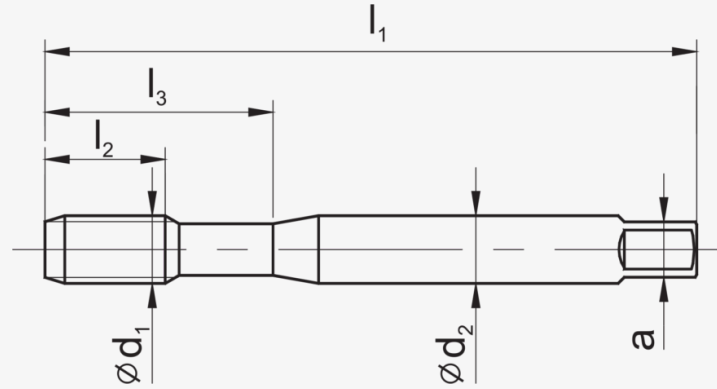

Application

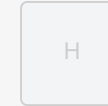
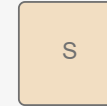
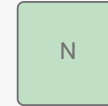
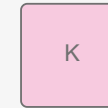
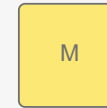

Dimensions

Index	Thread direction	$\varnothing d_1$	P	Pitch diameter tolerance	l_1	l_2	l_3	$\varnothing d_2$	a	Średnica otworu
-------	------------------	-------------------	---	--------------------------	-------	-------	-------	-------------------	-----	-----------------

C4-115301-0030		M3	0,50	6HX	56	5	18	3,5	2,7	2,50
-----------------------	--	----	------	-----	----	---	----	-----	-----	------

C4-115301-0040		M4	0,70	6HX	63	7	21	4,5	3,4	3,30
-----------------------	---	----	------	-----	----	---	----	-----	-----	------

C4-115301-0050		M5	0,80	6HX	70	8	25	6,0	4,9	4,20
-----------------------	---	----	------	-----	----	---	----	-----	-----	------

C4-115301-0060		M6	1,00	6HX	80	10	30	6,0	4,9	5,00
-----------------------	---	----	------	-----	----	----	----	-----	-----	------

C4-115301-0080		M8	1,25	6HX	90	13	35	8,0	6,2	6,80
-----------------------	---	----	------	-----	----	----	----	-----	-----	------

C4-115301-0100		M10	1,50	6HX	100	15	39	10,0	8,0	8,50
-----------------------	---	-----	------	-----	-----	----	----	------	-----	------

S-NC B-TC DIN-376/DIN-374



B-TC DIN-376/DIN-374

Taps dedicated to synchronous tapping.

Protection

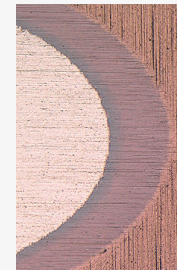

Tools are protected against wear and tear by TC coat developed by Fanar. Applied in state-of-the-art HiPIMS technology that guarantees homogenous coat structure and the highest crack resistance. Silicon contained in the coat allows machining hard and abrasive materials.



Select thread variant

Application

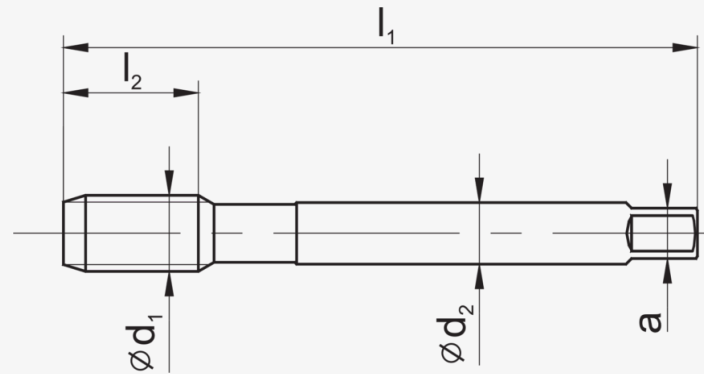
M



Dimensions

Index	Thread direction	$\varnothing d_1$	P	Pitch diameter tolerance	l_1	l_2	$\varnothing d_2$	a	Średnica otworu
D4-115301-0120		M12	1,75	6HX	110	18	9,0	7,0	10,20
D4-115301-0140		M14	2,00	6HX	110	20	11,0	9,0	12,00
D4-115301-0160		M16	2,00	6HX	110	20	12,0	9,0	14,00

C-R45-IK-TC DIN-371



HSSE-PM

TC

C (2-3P)

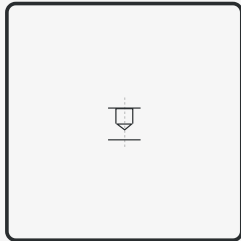

C-R45-IK-TC DIN-371

Taps dedicated to synchronous tapping.

Protection

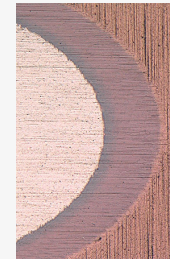

Tools are protected against wear and tear by TC coat developed by Fanar. Applied in state-of-the-art HiPIMS technology that guarantees

homogenous coat structure and the highest crack resistance. Silicon contained in the coat allows machining hard and abrasive materials.

Select thread variant

M

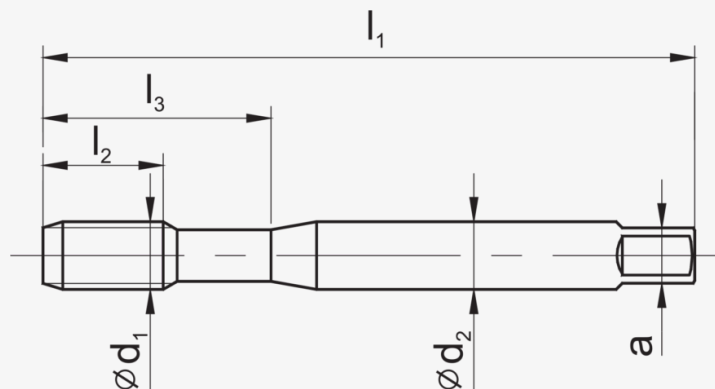

Application

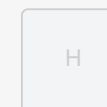
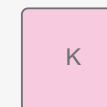
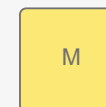
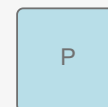

Dimensions

Index

Thread
direction

$\varnothing d_1$

P

Pitch
diameter
tolerance

l_1

l_2

l_3

$\varnothing d_2$

a

Średnica
otworu

C4-525351-0050



M5

0,80

6HX

70

8

25

6,0

4,9

4,20

C4-525351-0060



M6

1,00

6HX

80

10

30

6,0

4,9

5,00

C4-525351-0080



M8

1,25

6HX

90

13

35

8,0

6,2

6,80

C4-525351-0100



M10

1,50

6HX

100

15

39

10,0

8,0

8,50

S-NC C-R45-IK-TC DIN-376/DIN-374



C-R45-IK-TC DIN-376/DIN-374

Taps dedicated to synchronous tapping.

Protection

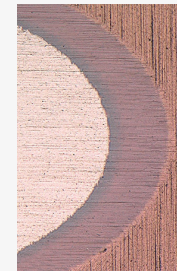

Tools are protected against wear and tear by TC coat developed by Fanar. Applied in state-of-the-art HiPIMS technology that guarantees homogenous coat structure and the highest crack resistance. Silicon contained in the coat allows machining hard and abrasive materials.

Select thread variant

M

Application

P

M

K

N

S

H

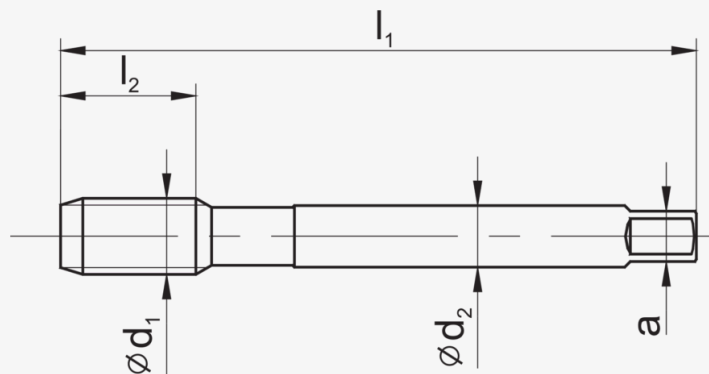

Dimensions

Index	Thread direction	$\varnothing d_1$	P	Pitch diameter tolerance	l_1	l_2	$\varnothing d_2$	a	Średnica otworu
D4-525351-0120	(RH) ↻	M12	1,75	6HX	110	18	9,0	7,0	10,20
D4-525351-0140	(RH) ↻	M14	2,00	6HX	110	20	11,0	9,0	12,00
D4-525351-0160	(RH) ↻	M16	2,00	6HX	110	20	12,0	9,0	14,00

S-NC C-R45-TC DIN-371



HSSE-PM

TC

C (2-3P)

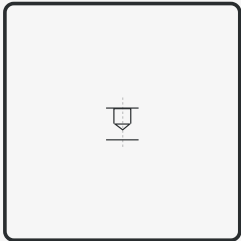

C-R45-TC DIN-371

Taps dedicated to synchronous tapping.

Protection



Tools are protected against wear and tear by TC coat developed by Fanar. Applied in state-of-the-art HiPIMS technology that guarantees

homogenous coat structure and the highest crack resistance. Silicon contained in the coat allows machining hard and abrasive materials.

Select thread variant

M

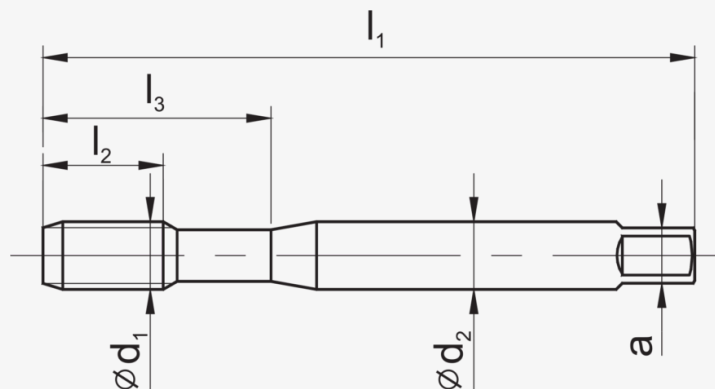

Application

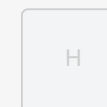
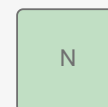
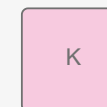
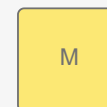
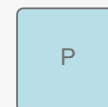

Dimensions

Index

Thread
direction

$\varnothing d_1$

P

Pitch
diameter
tolerance

l_1







l_2

l_3

$\varnothing d_2$

a

Średnica
otworu

C4-525301-0030		M3	0,50	6HX	56	5	18	3,5	2,7	2,50
C4-525301-0040		M4	0,70	6HX	63	7	21	4,5	3,4	3,30
C4-525301-0050		M5	0,80	6HX	70	8	25	6,0	4,9	4,20
C4-525301-0060		M6	1,00	6HX	80	10	30	6,0	4,9	5,00
C4-525301-0080		M8	1,25	6HX	90	13	35	8,0	6,2	6,80
C4-525301-0100		M10	1,50	6HX	100	15	39	10,0	8,0	8,50

S-NC C-R45-TC DIN-376/DIN-374



C-R45-TC DIN-376/DIN-374

Taps dedicated to synchronous tapping.

Protection

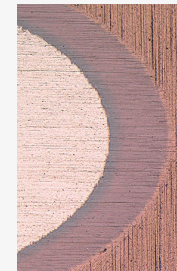

Tools are protected against wear and tear by TC coat developed by Fanar. Applied in state-of-the-art HiPIMS technology that guarantees homogenous coat structure and the highest crack resistance. Silicon contained in the coat allows machining hard and abrasive materials.

Select thread variant

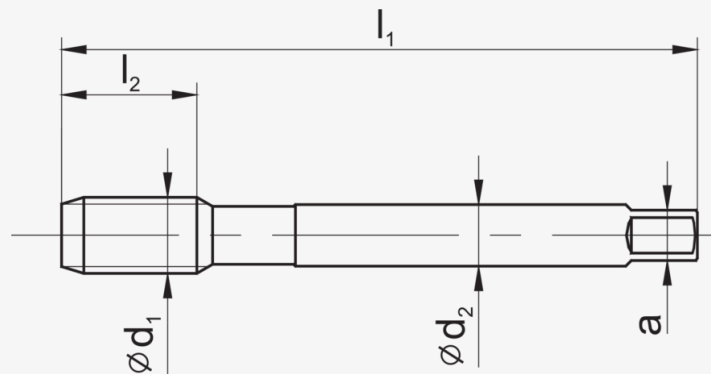

Application

P	M	K
N	S	H

Dimensions

Index	Thread direction	ød ₁	P	Pitch diameter tolerance	l ₁	l ₂	ød ₂	a	Średnica otworu
D4-525301-0120		M12	1,75	6HX	110	18	9,0	7,0	10,20
D4-525301-0140		M14	2,00	6HX	110	20	11,0	9,0	12,00
D4-525301-0160		M16	2,00	6HX	110	20	12,0	9,0	14,00

Архангельск (8182)63-90-72
 Астана (7172)727-132
 Астрахань (8512)99-46-04
 Барнаул (3852)73-04-60
 Белгород (4722)40-23-64
 Брянск (4832)59-03-52
 Владивосток (423)249-28-31
 Волгоград (844)278-03-48
 Вологда (8172)26-41-59
 Воронеж (473)204-51-73
 Екатеринбург (343)384-55-89
 Иваново (4932)77-34-06

Ижевск (3412)26-03-58
 Иркутск (395)279-98-46
 Казань (843)206-01-48
 Калининград (4012)72-03-81
 Калуга (4842)92-23-67
 Кемерово (3842)65-04-62
 Киров (8332)68-02-04
 Краснодар (861)203-40-90
 Красноярск (391)204-63-61
 Курск (4712)77-13-04
 Липецк (4742)52-20-81

Киргизия (996)312-96-26-47

Магнитогорск (3519)55-03-13
 Москва (495)268-04-70
 Мурманск (8152)59-64-93
 Набережные Челны (8552)20-53-41
 Нижний Новгород (831)429-08-12
 Новокузнецк (3843)20-46-81
 Новосибирск (383)227-86-73
 Омск (3812)21-46-40
 Орел (4862)44-53-42
 Оренбург (3532)37-68-04
 Пенза (8412)22-31-16

Россия (495)268-04-70

Пермь (342)205-81-47
 Ростов-на-Дону (863)308-18-15
 Рязань (4912)46-61-64
 Самара (846)206-03-16
 Санкт-Петербург (812)309-46-40
 Саратов (845)249-38-78
 Севастополь (8692)22-31-93
 Симферополь (3652)67-13-56
 Смоленск (4812)29-41-54
 Сочи (862)225-72-31
 Ставрополь (8652)20-65-13

Казахстан (772)734-952-31

Сургут (3462)77-98-35
 Тверь (4822)63-31-35
 Томск (3822)98-41-53
 Тула (4872)74-02-29
 Тюмень (3452)66-21-18
 Ульяновск (8422)24-23-59
 Уфа (347)229-48-12
 Хабаровск (4212)92-98-04
 Челябинск (351)202-03-61
 Череповец (8202)49-02-64
 Ярославль (4852)69-52-93