

Архангельск (8182)63-90-72
 Астана (7172)727-132
 Астрахань (8512)99-46-04
 Барнаул (3852)73-04-60
 Белгород (4722)40-23-64
 Брянск (4832)59-03-52
 Владивосток (423)249-28-31
 Волгоград (844)278-03-48
 Вологда (8172)26-41-59
 Воронеж (473)204-51-73
 Екатеринбург (343)384-55-89
 Иваново (4932)77-34-06

Ижевск (3412)26-03-58
 Иркутск (395)279-98-46
 Казань (843)206-01-48
 Калининград (4012)72-03-81
 Калуга (4842)92-23-67
 Кемерово (3842)65-04-62
 Киров (8332)68-02-04
 Краснодар (861)203-40-90
 Красноярск (391)204-63-61
 Курск (4712)77-13-04
 Липецк (4742)52-20-81

Киргизия (996)312-96-26-47

Магнитогорск (3519)55-03-13
 Москва (495)268-04-70
 Мурманск (8152)59-64-93
 Набережные Челны (8552)20-53-41
 Нижний Новгород (831)429-08-12
 Новокузнецк (3843)20-46-81
 Новосибирск (383)227-86-73
 Омск (3812)21-46-40
 Орел (4862)44-53-42
 Оренбург (3532)37-68-04
 Пенза (8412)22-31-16

Россия (495)268-04-70

Пермь (342)205-81-47
 Ростов-на-Дону (863)308-18-15
 Рязань (4912)46-61-64
 Самара (846)206-03-16
 Санкт-Петербург (812)309-46-40
 Саратов (845)249-38-78
 Севастополь (8692)22-31-93
 Симферополь (3652)67-13-56
 Смоленск (4812)29-41-54
 Сочи (862)225-72-31
 Ставрополь (8652)20-65-13

Казахстан (772)734-952-31

Сургут (3462)77-98-35
 Тверь (4822)63-31-35
 Томск (3822)98-41-53
 Тула (4872)74-02-29
 Тюмень (3452)66-21-18
 Ульяновск (8422)24-23-59
 Уфа (347)229-48-12
 Хабаровск (4212)92-98-04
 Челябинск (351)202-03-61
 Череповец (8202)49-02-64
 Ярославль (4852)69-52-93

<https://fanar.nt-rt.ru/> || frk@nt-rt.ru

DIN-352

General purpose machine taps. Made of HSS steel.

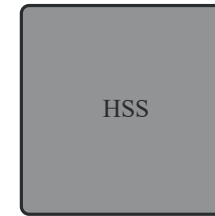

Application

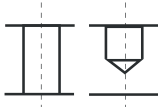

Variants

Variant	Type of hole	Type of chamfer	Type of grooves	Execution standard
DIN-352 		3P 2181/DIN-352	Straight	DIN-5157/DIN-

Machine taps DIN-352 DIN-352 / DIN-2181 / DIN-5157



HSS

3P



DIN-352

**DIN-352 / DIN-2181 /
DIN-5157**

General purpose taps – short design.

Select thread variant

M - RH

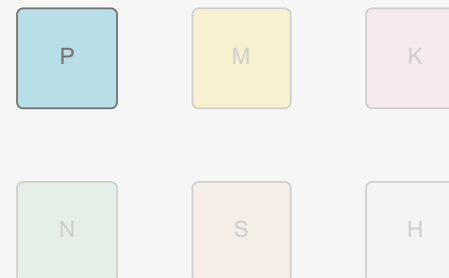
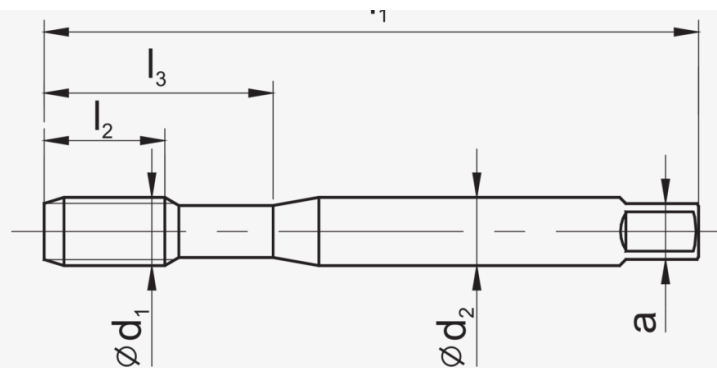

Dimensions

Index	Thread direction	ød ₁	P	Pitch diameter tolerance	l ₁	l ₂	l ₃	ød ₂	a	Średnica otworu
E1-131001-0030		M3	0,50	ISO2(6H)	40	11	18,0	3,5	2,7	2,5
E1-131001-0035		M3,5	0,60	ISO2(6H)	45	13	21,0	4,0	3,0	2,9

E1-131001-0040		M4	0,70	ISO2(6H)	45	13	21,0	4,5	3,4	3,3
-----------------------	---	----	------	----------	----	----	------	-----	-----	-----

E1-131001-0045		M4,5	0,75	ISO2(6H)	50	16	25,0	6,0	4,9	3,7
-----------------------	---	------	------	----------	----	----	------	-----	-----	-----

E1-131001-0050		M5	0,80	ISO2(6H)	52	16	26,0	6,0	4,9	4,2
-----------------------	---	----	------	----------	----	----	------	-----	-----	-----

E1-131001-0060		M6	1,00	ISO2(6H)	56	18	27,0	6,0	4,9	5,0
-----------------------	---	----	------	----------	----	----	------	-----	-----	-----

E1-131001-0070		M7	1,00	ISO2(6H)	56	18		6,0	4,9	6,0
-----------------------	---	----	------	----------	----	----	--	-----	-----	-----

E1-131001-0080		M8	1,25	ISO2(6H)	63	20		6,0	4,9	6,8
-----------------------	---	----	------	----------	----	----	--	-----	-----	-----

E1-131001-0090		M9	1,25	ISO2(6H)	63	20		7,0	5,5	7,8
-----------------------	---	----	------	----------	----	----	--	-----	-----	-----

E1-131001-0100		M10	1,50	ISO2(6H)	70	22		7,0	5,5	8,5
-----------------------	---	-----	------	----------	----	----	--	-----	-----	-----

E1-131001-0110

M11

1,50

ISO2(6H)

70

22

8,0

6,2

9,5

E1-131001-0120

M12

1,75

ISO2(6H)

80

24

9,0

7,0

10,2

E1-131001-0140

M14

2,00

ISO2(6H)

80

26

11,0

9,0

12,0

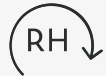
E1-131001-0160

M16

2,00

ISO2(6H)

80

27

12,0

9,0

14,0

E1-131001-0180

M18

2,50

ISO2(6H)

95

30

14,0

11,0

15,5

E1-131001-0200

M20

2,50

ISO2(6H)

95

32

16,0

12,0

17,5

E1-131001-0220

M22

2,50

ISO2(6H)

100

32

18,0

14,5

19,5

E1-131001-0240

M24

3,00

ISO2(6H)

110

34

18,0

14,5

21,0



E1-131001-0270



M27

3,00

ISO2(6H)

110

36

20,0

16,0

24,0

E1-131001-0300



M30

3,50

ISO2(6H)

125

40

22,0

18,0

26,5

E1-131001-0330



M33

3,50

ISO2(6H)

125

40

25,0

20,0

29,5

E1-131001-0360



M36

4,00

ISO2(6H)

150

50

28,0

22,0

32,0

E1-131001-0390



M39

4,00

ISO2(6H)

150

50

32,0

24,0

35,0

E1-131001-0420



M42

4,50

ISO2(6H)

150

56

32,0

24,0

37,5

E1-131001-0450



M45

4,50

ISO2(6H)

160

58

36,0

29,0

40,5

E1-131001-0480  M48 5,00 ISO2(6H) 180 65 36,0 29,0 43,0

E1-131001-0520  M52 5,00 ISO2(6H) 180 65 40,0 32,0 47,0

E1-131001-0560  M56 5,50 ISO2(6H) 180 70 40,0 32,0 50,5

E1-131001-0600  M60 5,50 ISO2(6H) 200 70 45,0 35,0 54,5

E1-131001-0640  M64 6,00 ISO2(6H) 220 75 50,0 39,0 58,0

E1-131001-0680  M68 6,00 ISO2(6H) 220 75 50,0 39,0 62,0

Архангельск (8182)63-90-72
Астана (7172)727-132
Астрахань (8512)99-46-04
Барнаул (3852)73-04-60
Белгород (4722)40-23-64
Брянск (4832)59-03-52
Владивосток (423)249-28-31
Волгоград (844)278-03-48
Вологда (8172)26-41-59
Воронеж (473)204-51-73
Екатеринбург (343)384-55-89
Иваново (4932)77-34-06

Ижевск (3412)26-03-58
Иркутск (395)279-98-46
Казань (843)206-01-48
Калининград (4012)72-03-81
Калуга (4842)92-23-67
Кемерово (3842)65-04-62
Киров (8332)68-02-04
Краснодар (861)203-40-90
Красноярск (391)204-63-61
Курск (4712)77-13-04
Липецк (4742)52-20-81

Киргизия (996)312-96-26-47

Магнитогорск (3519)55-03-13
Москва (495)268-04-70
Мурманск (8152)59-64-93
Набережные Челны (8552)20-53-41
Нижний Новгород (831)429-08-12
Новокузнецк (3843)20-46-81
Новосибирск (383)227-86-73
Омск (3812)21-46-40
Орел (4862)44-53-42
Оренбург (3532)37-68-04
Пенза (8412)22-31-16

Россия (495)268-04-70

Пермь (342)205-81-47
Ростов-на-Дону (863)308-18-15
Рязань (4912)46-61-64
Самара (846)206-03-16
Санкт-Петербург (812)309-46-40
Саратов (845)249-38-78
Севастополь (8692)22-31-93
Симферополь (3652)67-13-56
Смоленск (4812)29-41-54
Сочи (862)225-72-31
Ставрополь (8652)20-65-13

Казахстан (772)734-952-31

Сургут (3462)77-98-35
Тверь (4822)63-31-35
Томск (3822)98-41-53
Тула (4872)74-02-29
Тюмень (3452)66-21-18
Ульяновск (8422)24-23-59
Уфа (347)229-48-12
Хабаровск (4212)92-98-04
Челябинск (351)202-03-61
Череповец (8202)49-02-64
Ярославль (4852)69-52-93