

Архангельск (8182)63-90-72
Астана (7172)727-132
Астрахань (8512)99-46-04
Барнаул (3852)73-04-60
Белгород (4722)40-23-64
Брянск (4832)59-03-52
Владивосток (423)249-28-31
Волгоград (844)278-03-48
Вологда (8172)26-41-59
Воронеж (473)204-51-73
Екатеринбург (343)384-55-89
Иваново (4932)77-34-06

Ижевск (3412)26-03-58
Иркутск (395)279-98-46
Казань (843)206-01-48
Калининград (4012)72-03-81
Калуга (4842)92-23-67
Кемерово (3842)65-04-62
Киров (8332)68-02-04
Краснодар (861)203-40-90
Красноярск (391)204-63-61
Курск (4712)77-13-04
Липецк (4742)52-20-81
Киргизия (996)312-96-26-47

Магнитогорск (3519)55-03-13
Москва (495)268-04-70
Мурманск (8152)59-64-93
Набережные Челны (8552)20-53-41
Нижний Новгород (831)429-08-12
Новокузнецк (3843)20-46-81
Новосибирск (383)227-86-73
Омск (3812)21-46-40
Орел (4862)44-53-42
Оренбург (3532)37-68-04
Пенза (8412)22-31-16
Россия (495)268-04-70

Пермь (342)205-81-47
Ростов-на-Дону (863)308-18-15
Рязань (4912)46-61-64
Самара (846)206-03-16
Санкт-Петербург (812)309-46-40
Саратов (845)249-38-78
Севастополь (8692)22-31-93
Симферополь (3652)67-13-56
Смоленск (4812)29-41-54
Сочи (862)225-72-31
Ставрополь (8652)20-65-13
Казахстан (772)734-952-31

Сургут (3462)77-98-35
Тверь (4822)63-31-35
Томск (3822)98-41-53
Тула (4872)74-02-29
Тюмень (3452)66-21-18
Ульяновск (8422)24-23-59
Уфа (347)229-48-12
Хабаровск (4212)92-98-04
Челябинск (351)202-03-61
Череповец (8202)49-02-64
Ярославль (4852)69-52-93

<https://fanar.nt-rt.ru/> || frk@nt-rt.ru

HRC40

The HRC40 hand taps are available in 2- and 3-piece sets with a pilot nose. They are designed to cut or calibrate threads in toughened steel up to 42 HRC. The length of the finishing tap chamfer is $\sim 3xP$.

The tool is made of HSSE-PM steel obtained by powder metallurgy technology, which guarantees a uniform structure conducive to high resistance to wear.

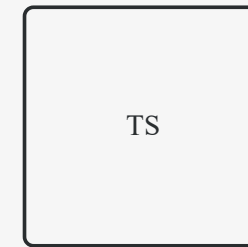
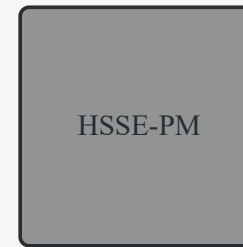

Application

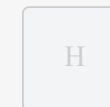
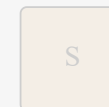
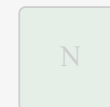
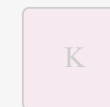
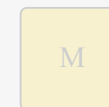
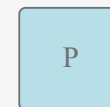

Variants

Variant	Chamfer	Coating type	Execution standard
Finisher	3P	TS	DIN-2181/DIN-5157/DIN-352
Set of 2 pcs.		TS	DIN-5157/DIN-2181
Set of 3 pcs.		TS	DIN-352



HSSE-PM

TS

3P



Finisher

The HSSE-PM hand 2- and 3-piece sets for toughened steel up to 42 HRC and for calibration.

Protection

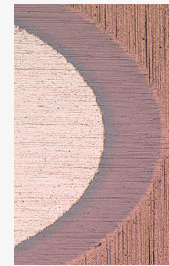

The TS coat developed by Fanar protects the tools against wear and tear. Applied in state-of-the-art HiPIMS technology that guarantees homogenous coat structure and the highest crack resistance. Silicon contained in the coat allows machining hard and abrasive materials.

Select thread variant

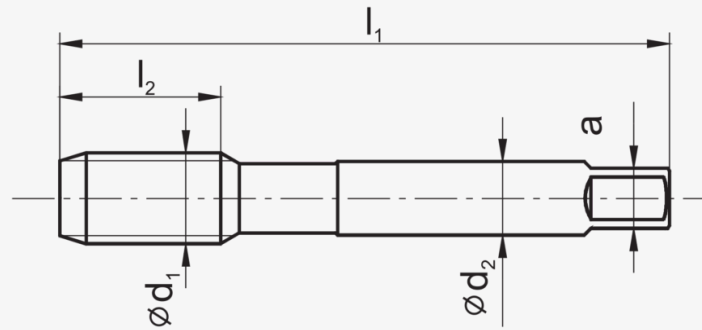

Application

P	M	K
N	S	H

Dimensions

Index

Thread direction

Thread size

P

Pitch diameter tolerance

l_1

l_2

$\varnothing d_2$

a

Tapping hole diameter

A4-203D51-0030		M3	0,50	6HX	40	10	3,5	2,7	2,5
A4-203D51-0040		M4	0,70	6HX	50	13	6,0	4,9	3,3
A4-203D51-0050		M5	0,80	6HX	50	16	6,0	4,9	4,2
A4-203D51-0060		M6	1,00	6HX	56	19	6,0	4,9	5,0
A4-203D51-0080		M8	1,25	6HX	63	22	6,0	4,9	6,8
A4-203D51-0100		M10	1,50	6HX	70	25	7,0	5,5	8,5
A4-203D51-0120		M12	1,75	6HX	75	30	9,0	7,0	10,2
A4-203D51-0160		M16	2,00	6HX	80	32	12,0	9,0	14,0
A4-203D51-0200		M20	2,50	6HX	95	40	16,0	12,0	17,5



Set of 2 pcs.

The HSSE-PM hand 2- and 3-piece sets for toughened steel up to 42 HRC and for calibration.

Protection

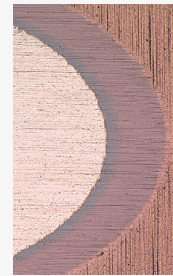

The TS coat developed by Fanar protects the tools against wear and tear. Applied in state-of-the-art HiPIMS technology that guarantees homogenous coat structure and the highest crack resistance. Silicon contained in the coat allows machining hard and abrasive materials.





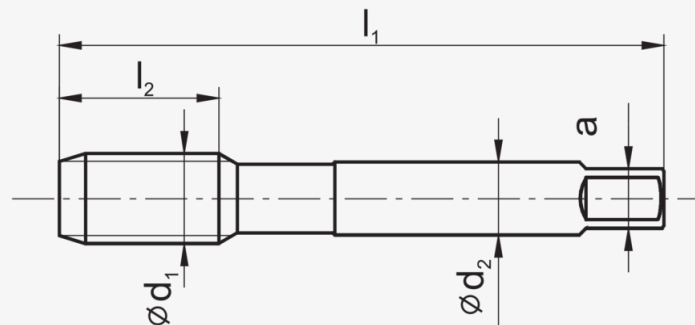

Select thread variant

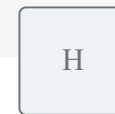
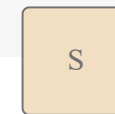
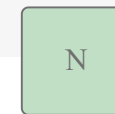
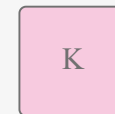
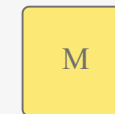
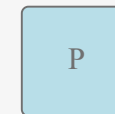

Application



Dimensions

Index	Thread direction	Thread size	1"/P	P	l ₁	l ₂	ød ₂	a	Tapping hole diameter
A4-225D51-3123		G-1/8"	28	0,907	63	18	7,0	5,5	8,80
A4-225D51-3127		G-1/4"	19	1,337	70	22	11,0	9,0	11,80
A4-225D51-3129		G-3/8"	19	1,337	70	22	12,0	9,0	15,25
A4-225D51-3131		G-1/2"	14	1,814	80	22	16,0	12,0	19,00



HSSE-PM

TS

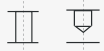

DIN-352

Set of 3 pcs.

The HSSE-PM hand 2- and 3-piece sets for toughened steel up to 42 HRC and for calibration.

Protection

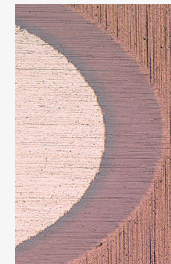

The TS coat developed by Fanar protects the tools against wear and tear. Applied in state-of-the-art HiPIMS technology that guarantees homogenous coat structure and the highest crack resistance. Silicon contained in the coat allows machining hard and abrasive materials.

Select thread variant

M

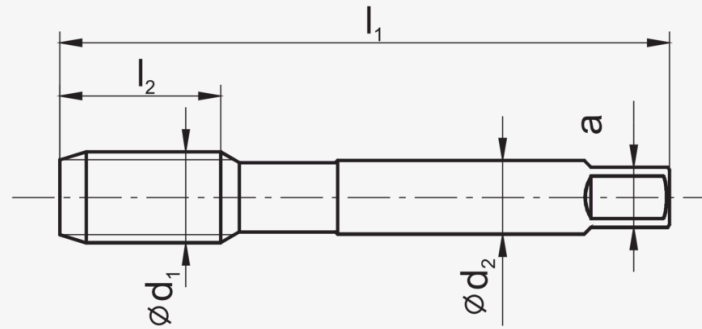









Application

Application selection grid:

- P (Blue)
- M (Yellow)
- K (Pink)
- N (Green)
- S (Orange)
- H (Light Blue)

Dimensions

Index	Thread direction	Thread size	P	Pitch diameter tolerance	l_1	l_2	$\varnothing d_2$	a	Tapping hole diameter
A4-235D51-0030	(RH)	M3	0,50	6HX	40	10	3,5	2,7	2,5

A4-235D51-0040		M4	0,70	6HX	50	13	6,0	4,9	3,3
A4-235D51-0050		M5	0,80	6HX	50	16	6,0	4,9	4,2
A4-235D51-0060		M6	1,00	6HX	56	19	6,0	4,9	5,0
A4-235D51-0080		M8	1,25	6HX	63	22	6,0	4,9	6,8
A4-235D51-0100		M10	1,50	6HX	70	25	7,0	5,5	8,5
A4-235D51-0120		M12	1,75	6HX	75	30	9,0	7,0	10,2
A4-235D51-0160		M16	2,00	6HX	80	32	12,0	9,0	14,0
A4-235D51-0200		M20	2,50	6HX	95	40	16,0	12,0	17,5

Архангельск (8182)63-90-72
Астана (7172)727-132
Астрахань (8512)99-46-04
Барнаул (3852)73-04-60
Белгород (4722)40-23-64
Брянск (4832)59-03-52
Владивосток (423)249-28-31
Волгоград (844)278-03-48
Вологда (8172)26-41-59
Воронеж (473)204-51-73
Екатеринбург (343)384-55-89
Иваново (4932)77-34-06

Ижевск (3412)26-03-58
Иркутск (395)279-98-46
Казань (843)206-01-48
Калининград (4012)72-03-81
Калуга (4842)92-23-67
Кемерово (3842)65-04-62
Киров (8332)68-02-04
Краснодар (861)203-40-90
Красноярск (391)204-63-61
Курск (4712)77-13-04
Липецк (4742)52-20-81

Киргизия (996)312-96-26-47

Магнитогорск (3519)55-03-13
Москва (495)268-04-70
Мурманск (8152)59-64-93
Набережные Челны (8552)20-53-41
Нижний Новгород (831)429-08-12
Новокузнецк (3843)20-46-81
Новосибирск (383)227-86-73
Омск (3812)21-46-40
Орел (4862)44-53-42
Оренбург (3532)37-68-04
Пенза (8412)22-31-16

Россия (495)268-04-70

Пермь (342)205-81-47
Ростов-на-Дону (863)308-18-15
Рязань (4912)46-61-64
Самара (846)206-03-16
Санкт-Петербург (812)309-46-40
Саратов (845)249-38-78
Севастополь (8692)22-31-93
Симферополь (3652)67-13-56
Орел (4862)44-53-42
Сочи (862)225-72-31
Ставрополь (8652)20-65-13

Казахстан (772)734-952-31

Сургут (3462)77-98-35
Тверь (4822)63-31-35
Томск (3822)98-41-53
Тула (4872)74-02-29
Тюмень (3452)66-21-18
Ульяновск (8422)24-23-59
Уфа (347)229-48-12
Хабаровск (4212)92-98-04
Челябинск (351)202-03-61
Череповец (8202)49-02-64
Ярославль (4852)69-52-93